

WIDOK Z BOKU
1:20

RT-99/4 szt. 8

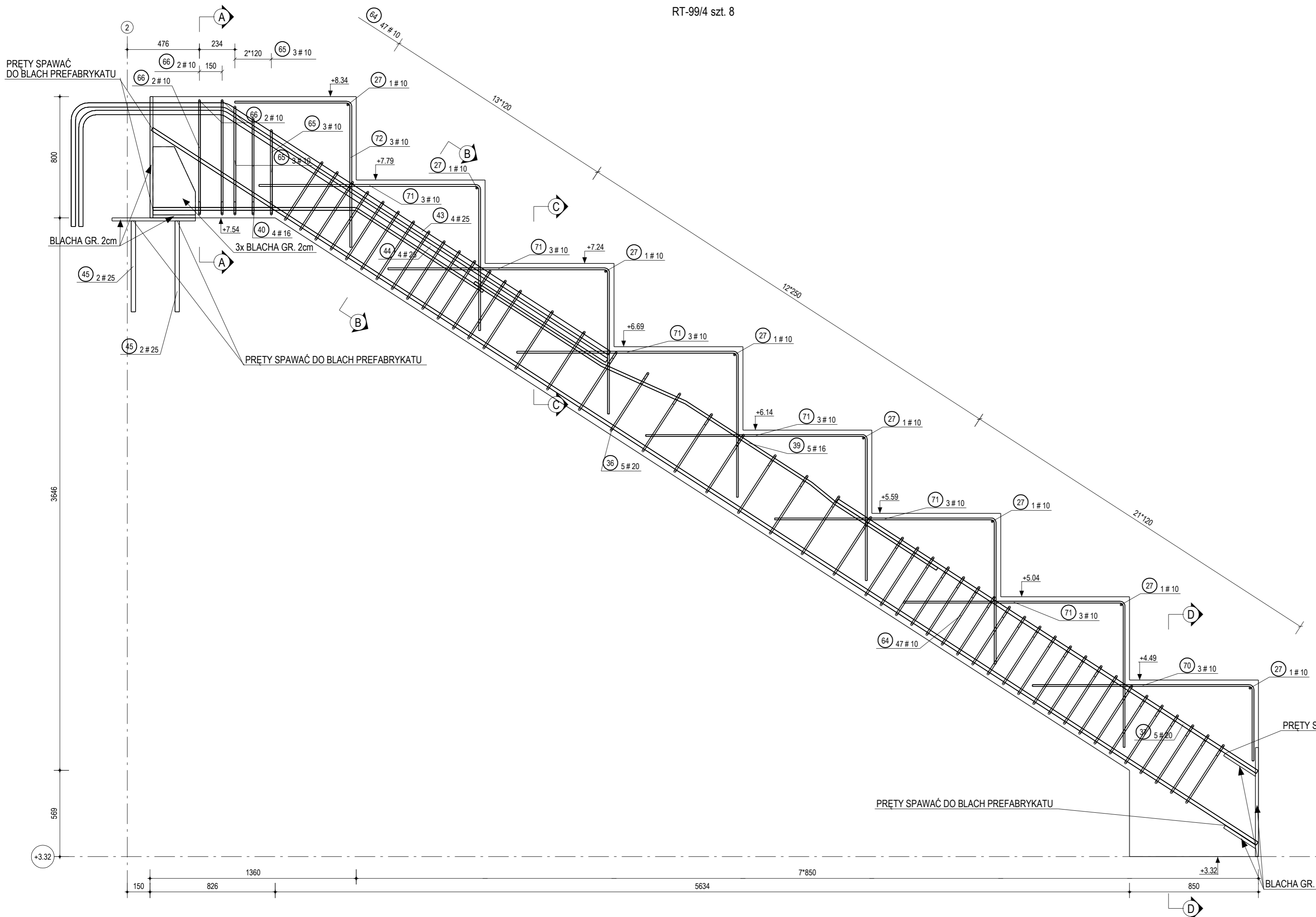

PRZEKRÓJ D - D
1:20

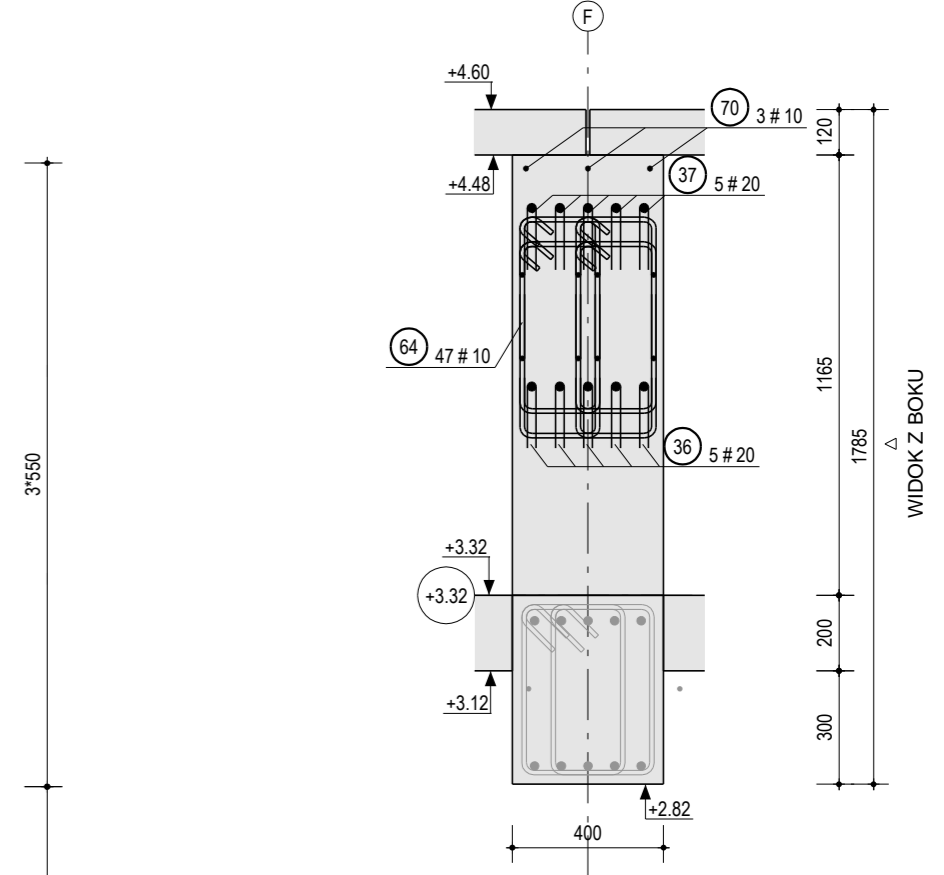

PRZEKRÓJ A - A
1:20

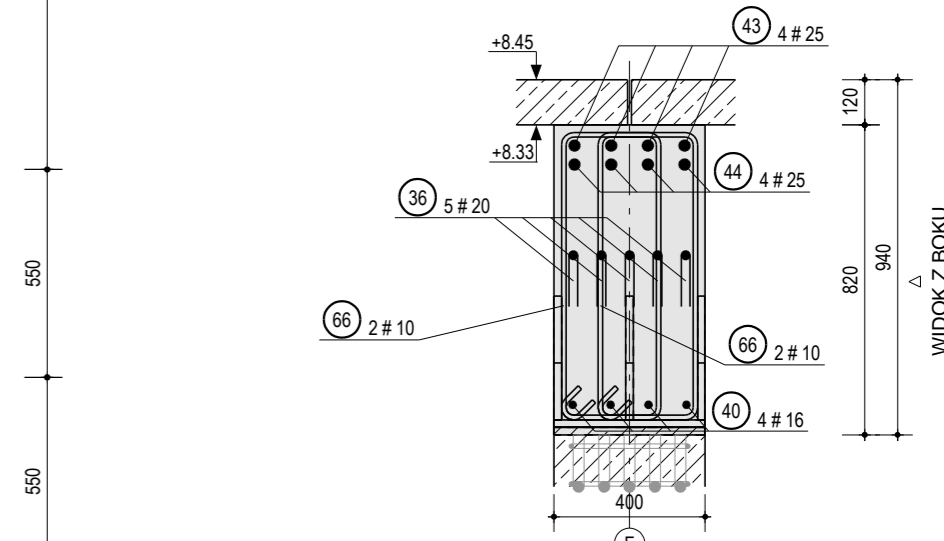

PRZEKRÓJ B - B
1:20

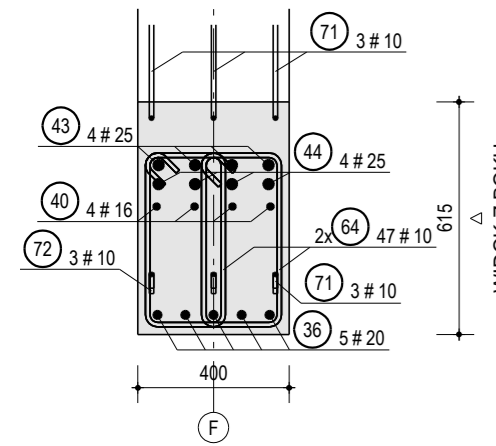

PRZEKRÓJ C - C
1:20

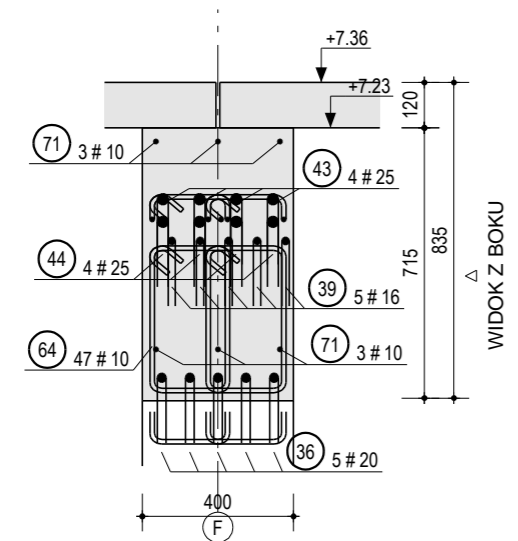

39	# 16	L= 3597	40	# 16	L= 2336	43	# 25	L= 4775	44	# 25	L= 4657	64	# 10	L= 1432	65	# 10	L= 1642	66	# 10	L= 2135	70	# 10	L= 1940	71	# 10	L= 2400
RT		Unkn	RT		3.1	RT		4.2	RT		4.2	RT		48	RT		48	RT		48	RT		2.1	RT		2.1
72	# 10	L= 1710	RT		770	RT		963	RT		2.1	RT		963	RT		963	RT		963	RT		963	RT		963

ZESTAWIENIE STALI ZBROJENIOWEJ												ZESTAWIENIE ZBIORCZE													
ZESTAWIENIE ZBROJENIA DLA												ZESTAWIENIE ZBIORCZE													
POZYCJA RT-99/4 SZT. 8												MATERIAL C30/37													
MASA STALI (kg) 467.16 / 3737.30												MASA ŁĄCZNE (kg) 3737.2													
SERIA	NR	NAZWA	SZT.	KLASA	D	L	KOD	A	B	C	D	E	F	G	H	I	J	K	L	M	N	O	P	Q	R
RT	27	64	850SP	10	350	1	350																		
RT	37	40	850SP	20	800	1	800																		
RT	38	40	850SP	20	3300	1	3300																		
RT	39	40	850SP	16	3597	Unkn																			
RT	40	32	850SP	16	2336	3.1	1339	1002																	
RT	41	32	850SP	25	4775	4.2	616	1022																	
RT	42	32	850SP	25	4657	4.2	766	957																	
RT	43	752	850SP	10	1432	48	82	460	211	460	211	82													
RT	44	32	850SP	10	2135	48	82	760	263	760	263	82													
RT	45	24	850SP	10	1940	2.1	1460	503																	
RT	46	144	850SP	10	2400	2.1	1460	963																	
RT	47	24	850SP	10	1710	2.1	963	770																	

PRIMES
structural engineering

ul. Sobótki 9
80-247 Gdańsk
tel.: +48(58)3424420
biuro@primes.pl
www.primes.pl

Projekt hali sportowo-widowskowej wraz z zagospodarowaniem terenu przy ul. Zarzeczce 26 oraz parkingiem przy ul. Grunwaldzkiej SUWAŁKI, UL. ZARZECZE 26 UL. GRUNWALDZKA DZ. 31349/9, 31359/2, obręb 07

Miasto Suwałki
ul. Mickiewicza 1, 16-400 Suwałki

PROJEKT WYKONAWCZY

KONSTRUKCJA

PREFABRYKAT RAMY TRYBUNY POŁUDNIOWEJ 1 PIĘTRA RT-99/4

inż. Daniel Śladowski
upr. bud. POM0091/POOK/06

mgr inż. Dawid Szpilewski
upr. bud. POM0121/POOK/08

MAJ 2017 779 K 05 PO 09 0